

夹布油封使用说明书

Instruction for Usage of Clip Cloth Oil Seals

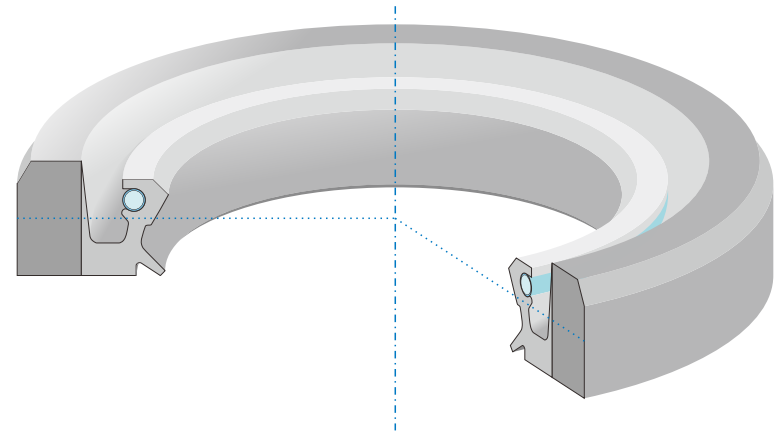

广州国机密封科技有限公司
Guangzhou SINOMACH Sealing Technology Co.,Ltd.



地址:广州市黄埔区新瑞路2号

电话:+86 20 32385289

网址:www.gyseals.com



| | | |
|----------|---|-----------|
| 1 | 油封简介 | 01 |
| | Introduction of Oil Seals | |
| 2 | 油封安装设备的要求 | 02 |
| | Requirements for Oil Seal Installation Equipment | |
| 2.1 | 轴的材料 | 02 |
| | Material of Shaft | |
| 2.2 | 轴和沟槽的设计 | 02 |
| | Design of Shaft and Groove | |
| 3 | 影响油封密封效果的几大因素 | 04 |
| | Several Major Factors Affecting the Sealing Effect of Oil Seal | |
| 3.1 | 介质 | 04 |
| | Medium | |
| 3.2 | 温度 | 04 |
| | Temperature | |
| 3.3 | 润滑 | 05 |
| | Lubrication | |
| 3.4 | 压力 | 05 |
| | Pressure | |
| 3.5 | 速度 | 06 |
| | Speed | |
| 4 | 油封的安装 | 07 |
| | Installation of Oil Seals | |
| 4.1 | 安装前准备 | 07 |
| | Preparation before Installation | |
| 4.2 | 安装 | 08 |
| | Installation | |
| 5 | 油封的维护 | 10 |
| | Maintenance of Oil Seals | |
| 5.1 | 日常维护注意事项 | 10 |
| | Precautions for Daily Maintenance | |
| 5.2 | 在线更换方法及步骤 | 12 |
| | Online Replacement Methods and Steps | |
| 6 | 油封的存储 | 13 |
| | Storage of Oil Seals | |
| 6.1 | 油封在存储过程中可能遇到的危害 | 13 |
| | Possible Hazards of Oil Seals during Storage | |
| 6.2 | 油封的存储时间 | 14 |
| | Storage Period of Oil Seals | |

1

油封简介
Introduction of Oil Seals

油封是用作封油的机械元件，又称旋转轴唇形密封圈。常见的油封种类包括标准骨架油封（内骨架、外骨架）、无骨架油封（J型、Z型）以及夹布油封等。常见的夹布油封主要由橡胶夹织物（夹布）肩部及纯胶唇口部位组成，其关键参数包括内径、外径、高度、腰高、腰厚等，如下图所示：

Oil seals are mechanical components used to seal oil, and they are also known as rotary shaft self-seal packings. Common types of oil seals include standard skeleton oil seals (inner skeleton and outer skeleton), skeleton-free oil seals (J-type and Z-type) and clip cloth oil seals. The common clip cloth oil seal is mainly composed of rubber clip textile (cloth) shoulder and pure rubber lip. Its key parameters include inner diameter, outer diameter, height, waist height, waist thickness, etc., as shown in the following figure.

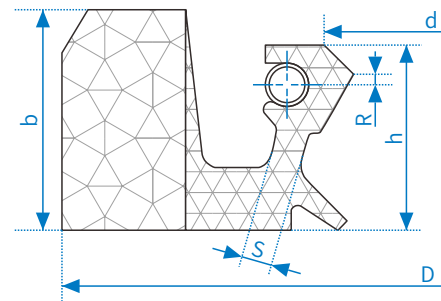

Figure 1-1 夹布油封关键尺寸
Key dimensions of clip cloth oil seal

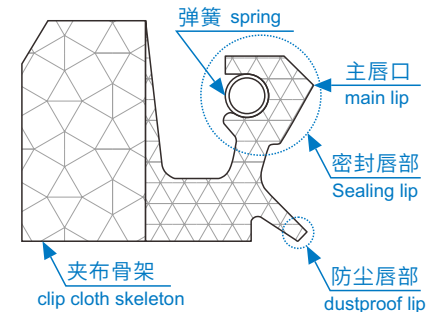

Figure 1-2 纯胶唇口部位组成
Composition of pure rubber lip

油封的密封唇口直径小于轴径，使唇口接触轴便产生一定的抱紧力；油封的金属弹簧对轴产生径向箍紧力；油封的腰部对轴产生一定的弹力。这三个力的叠加，便使油封对轴产生了接触压力。这个压力在金属弹簧位置和唇口形状的调节下呈集中分布。油封的工作机理就是依靠接触压力呈集中分布，进而在接触面上形成边界润滑，达到密封效果。油封的密封性能是相对的，即使是性能很好的密封也仍然存在着磨损和微量“泄漏”。所以在设计油封产品时，应充分考虑油封的材料选择、油封唇口的过盈量和几何形状、轴的加工及使用等方面，从而提高油封的工作性能和使用寿命。

The diameter of the sealing lip of the oil seal is smaller than the shaft diameter, so that the lip contacts the shaft to generate a certain holding force; The metal spring of the oil seal generates radial clamping force on the shaft; The waist of the oil seal generates a certain elasticity to the shaft. The superposition of these three forces causes the oil seal to generate contact pressure on the shaft. This pressure is distributed centrally under the adjustment of the position of the metal spring and the shape of the lip. The working mechanism of the oil seal is to form boundary lubrication on the contact surface so as to achieve the sealing effect relying on the concentrated distribution of contact pressure. The sealing performance of oil seal is relative, and even if the seal with good performance still has wear and trace "leakage". Therefore, when designing oil seal products, full consideration should be given to the material selection of the oil seal, the magnitude of interference and geometric shape of the oil seal lip, the processing and use of the shaft, etc., so as to improve the working performance and service life of the oil seal.

2 油封安装设备的要求 Requirements for Oil Seal Installation Equipment

2.1 轴的材料 Material of Shaft

轴的材料为碳钢、不锈钢。高速时表面镀铬，硬度达到洛氏 HRC40~55，镀层不能太薄，避免剥落；需要调质处理的轴，调质时间不能过短，速度要慢，以确保调质表面均匀。

The material of shaft is carbon steel and stainless steel. At high speed, the surface is chrome plated, the hardness reaches Rockwell HRC 40 ~ 55, and the coating cannot be too thin to avoid peeling off; For shafts requiring quenching and tempering, the quenching and tempering time should not be too short and the speed should be slow to ensure uniform quenching and tempering surface.

2.2 轴和沟槽的设计 Design of Shaft and Groove

轴的表面必须光滑，没有毛刺和刮痕，以免伤害密封件唇部；螺旋状的加工痕迹会产生泵吸效应，从而导致泄漏，建议对油封安装区域进行研磨，使工作表面粗糙度控制在 Ra0.1~0.8 μ m。表面光洁度随线速度增加而增大(光洁度绝对值变小)，但过于光滑的表面不推荐使用。

The surface of the shaft must be smooth and free from burrs and scratches to avoid damaging the lip of the seal; Helical machining marks will produce pumping effect, resulting in leakage. It is recommended to grind the oil seal installation area to control the roughness of the working surface to Ra 0.1 ~ 0.8 μ m. The surface smoothness increases with the increase of linear speed (the absolute value of smoothness decreases), but the surface that is too smooth is not recommended.

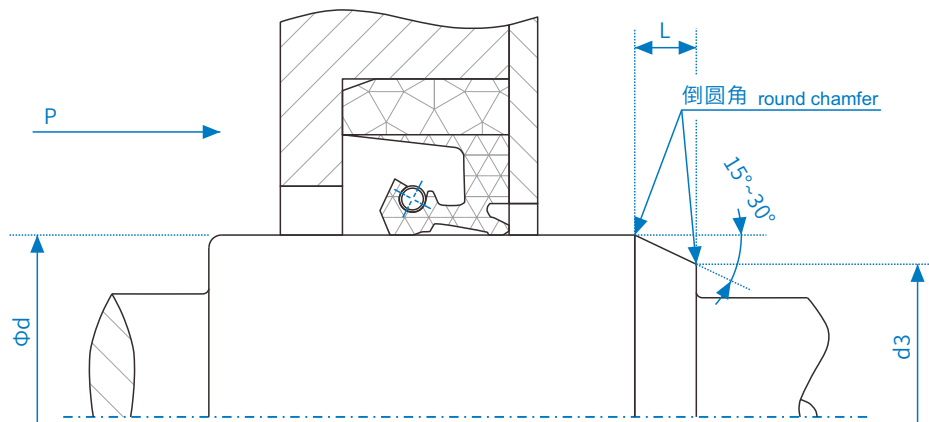

Figure 2-1 油封的安装
Installation of oil seals

为便于安装并尽量减小唇口的损坏，轴端部应加工15~30°的倒角，倒角长度参照下图所示。

In order to facilitate installation and minimize lip damage, the shaft end should be chamfered at 15 ~ 30 degrees. The chamfer length is shown in the following figure.

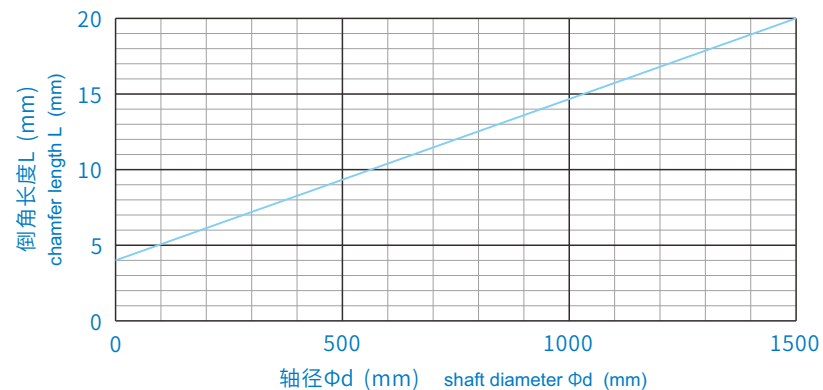

Figure 2-2 倒角长度与轴径关系
Relationship between chamfer length and shaft diameter

3 影响油封密封效果的几大因素 Several Major Factors Affecting the Sealing Effect of Oil Seal

3.1 介质 Medium

材料在不同密封介质环境下，表现出不同的性能，下表为常见的油封材料耐介质性能表。

The materials show different performances in different sealing medium environments. The following table shows the medium resistance performance of common oil seal materials.

Table 3-1 材料介质耐受性能表
Material medium tolerance performance table

| 材料 materials | 介质 medium | ASTM 1号油 ASTM 1# oil | ASTM 2号油 ASTM 2# oil | 水 water | 空气 air | 盐酸10% hydrochloric acid 10% | 臭氧 ozone |
|-----------------|--------------|-------------------------|-------------------------|------------|-----------|-----------------------------------|-------------|
| 丁腈橡胶 NBR | | 1 | 1 | 1 | 1 | 1 | 4 |
| 氢化丁腈橡胶 HNBR | | 1 | 1 | 1 | 1 | 1 | 1 |
| 三元乙丙橡胶 EPDM | | 4 | 4 | 1 | 1 | 1 | 1 |
| 聚丙烯酸酯橡胶 ACM | | 1 | 1 | 4 | 1 | 4 | 2 |
| 聚氨酯橡胶 PU | | 1 | 1 | 2 | 1 | 4 | 1 |
| 氟橡胶 FKM | | 1 | 1 | 1 | 1 | 1 | 1 |

注：1 推荐使用；2 可考虑使用；3 不推荐使用；4 不能使用。

Note: 1 Recommended; 2 Can be considered; 3 Not recommended; 4 Cannot be used.

3.2 温度 Temperature

低温会使唇口橡胶变脆易碎，高温会使其老化变硬。提高旋转速度，不良的表面质量、不良的润滑都可以产生过多的摩擦热，使密封唇口的温度超过介质温度50°C。

Low temperature will make lip rubber brittle, while high temperature will make it aging and hard. Poor surface quality and poor lubrication can generate excessive friction heat when the rotation speed is increased, to make the temperature of the sealing lip to exceed the medium temperature by 50°C.

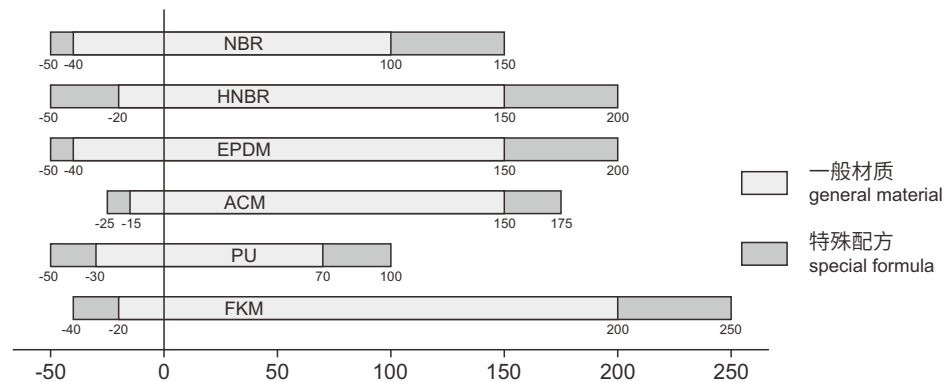

Figure 3-1 材料适用温度范围(正常工作1000h)
Applicable temperature range of materials (Normal operation for 1000h)

3.3 润滑 Lubrication

良好的润滑是保证产品使用寿命的关键，在产品使用过程中，应保证主唇、副唇处于良好的润滑状态，避免发生干摩擦。

Good lubrication is the key to ensure the service life of the product. During the use of the product, the main lip and the auxiliary lip should be kept in good lubrication state to avoid dry friction.

3.4 压力 Pressure

压力的效应是将密封唇口与轴的接触面积增大，温度升高，允许的速度下降，如图3-1所示，若压力升至5Mpa，允许的速度将为0。

The effect of the pressure is to increase the contact area between the sealing lip and the shaft, increase the temperature and decrease the allowable speed, as shown in Figure 3-1. If the pressure rises to 5Mpa, the allowable speed will be 0.

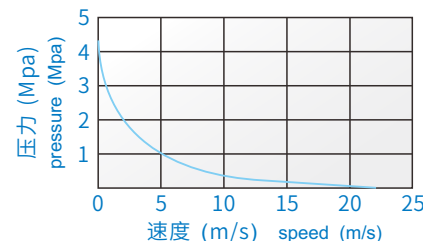

Figure 3-2 压力与速度关系
Relationship between pressure and speed

3.5 速度 Speed

不同设计的油封，工作时产生的摩擦力不同，导致温升情况也不同。因此不同设计的密封元件其最大使用圆周线速度也有所差异，图3-2列出了常用材料制成的密封件所允许使用的最大线速度的约值，测试时无压力变化，润滑及冷却状况良好。

Different designs of oil seals produce different friction forces during operation, resulting in different temperature rise. Therefore, the maximum circumferential linear speeds of sealing elements of different designs are also different. Figure 3-2 lists the approximate values of the maximum circumferential linear speeds allowed for sealing elements made of common materials. There is no pressure change during testing, and the lubrication and cooling conditions are good.

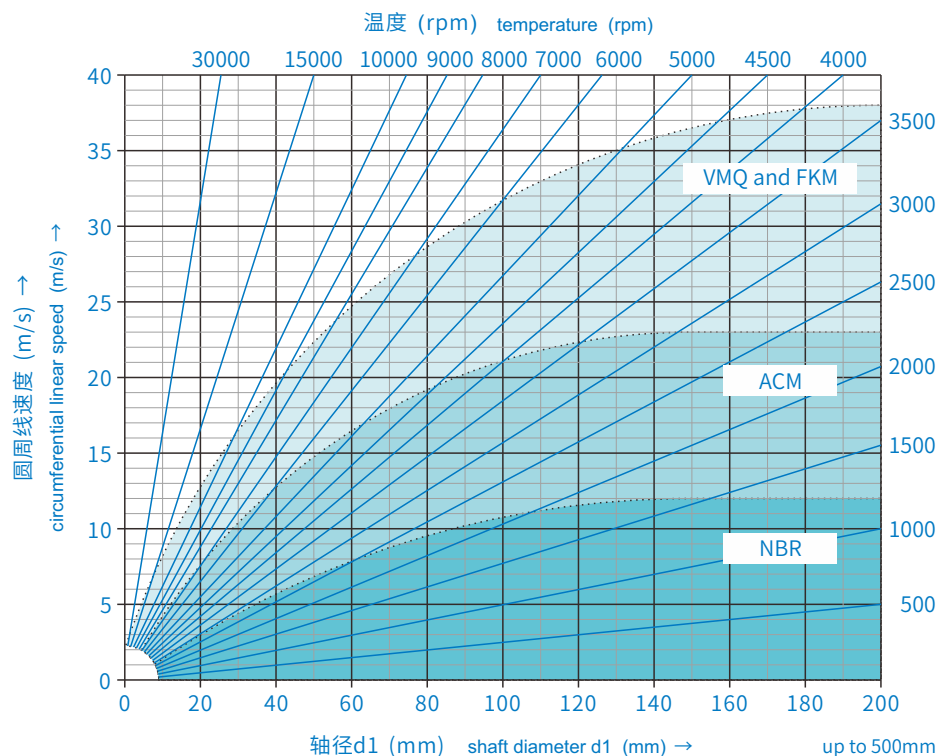

Figure 3-3 在无压状态时允许的速度
Allowable speeds in non-pressure state

4 油封的安装 Installation of Oil Seals

细心安装是保证密封良好性能的先决条件，针对不同设备密封现场安装情况，安装过程会有一些针对性的要求。具体操作要求如下：

Careful installation is a prerequisite to ensure good sealing performance. According to the sealing field installation of different equipment, there will be some specific requirements during the installation process. Specific operation requirements are as follows:

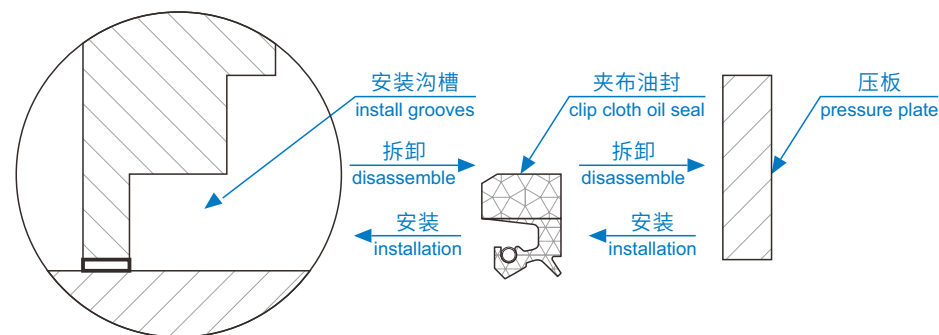

Figure 4-1 安装拆卸顺序示意图
Schematic diagram of installation and disassembly sequence

4.1 安装前准备 Preparation before Installation

4.1.1 安装端盖 Installing the end cover

将端盖安装到位，务必保证端盖与轴的同心度，以此确保密封件与轴的同心度。When the end cover is installed in place, be sure to ensure the concentricity between the end cover and the shaft, so as to ensure the concentricity between the seal and the shaft.

4.1.2 清洁与润滑 Cleaning and lubrication

轴表面与腔体孔内面确认无附着的防锈油或沙尘等异物，如有，须予以清洁。用汽油等溶剂清洗时，务必擦拭干净。用压缩空气喷射，可清理不易观察的部位，效果显著。

Confirm that the surface of the shaft and the inner surface of the cavity bore are free of foreign matters such as anti-rust oil or sand dust attached; If any, they must be cleaned. When cleaning with solvents such as gasoline, be sure to wipe it clean. The parts that are not easy to observe can be cleaned up by injection with compressed air, and the effect is remarkable.

腔体孔内面、倒角部分以及油封在通过轴端与轴时，不应有毛刺及缺陷，如有可抛光处理。

The inner surface of the cavity hole, the chamfered part and the oil seal shall be free from burrs and defects when the oil seal passes through the shaft end and shaft; If any, they can be polished.

确认唇口接触轴面时无缺陷及锈蚀，轴表面的缺陷与锈蚀是泄漏的直接原因。

Confirm that there are no defects and rust when the lip contacts the shaft surface. Defects and rust on the shaft surface are the direct causes of leakage.

检查油封是否完好无损；确认油封没有附着砂、尘等异物的油封。不要用硬物摩擦油封唇口端部，以免损伤密封件。

Check whether the oil seal is in good condition; Confirm that the oil seal is free of foreign bodies such as sand and dust. Do not rub the end of the oil seal lip with hard objects, in order to avoid damaging the seal.

4.2 安装 Installation

4.2.1

在沟槽腔体内面与轴表面均匀涂抹润滑脂，须保证全部涂抹到位。在双唇口之间涂抹润滑脂，以便于油封的安装，防止密封件损伤。

Apply grease evenly on the inner surface of groove cavity and the shaft surface, and ensure all grease is applied in place. Apply grease between the lips to facilitate the installation of the oil seal and prevent damage to the seal.

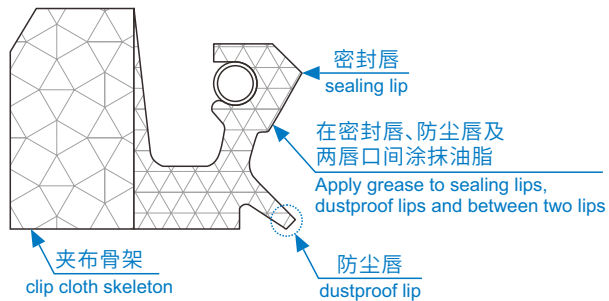

Figure 4-2 密封件油脂涂抹位置示意图
Schematic diagram of grease coating position of sealing element

4.2.2

将油封水平压入沟槽内，保证油封四周受力均匀。如无法通过手挤压进入沟槽，可借用平整的木板与橡胶锤，均匀地敲击密封件圆周，须保证密封件是水平均匀进入沟槽。不能先将一侧安装到位后压入另一侧，这会造成倾斜安装，将导致泄漏发生的可能。

Press the oil seal horizontally into the groove to ensure uniform stress around the oil seal. If it is impossible to squeeze it into the groove by hand, a flat wood board and a rubber hammer can be used to strike the circumference of the seal evenly to ensure that the sealing element enters the groove horizontally and evenly. You cannot install one side in place first and then press the other side in, and it will lead to inclined installation and the possibility of leakage.

4.2.3

安装过程中，时刻注意保证弹簧处于弹簧槽内，密封唇口处于正确状态。待密封件完全进入沟槽内，检查唇口部分与弹簧是否处于工作状态，即弹簧在弹簧槽内，唇口部分没有出现翻转。

During installation, always pay attention to ensure that the spring is in the spring groove and the sealing lip is in the correct state. When the sealing element completely enters the groove, check whether the lip part and the spring are in working state, i.e. the spring is in the spring groove, and the lip part does not turn over.

4.2.4

密封件安装完成后再安装压板，在压板紧固时，须尽可能地保证压板在水平均匀受力的下紧固。

The pressure plate shall be installed after the sealing element is installed. When the pressure plate is tightened, the pressure plate shall be tightened under horizontal and uniform stress as much as possible.

4.2.5

清洁现场，完成安装。

Clean the site and complete the installation.

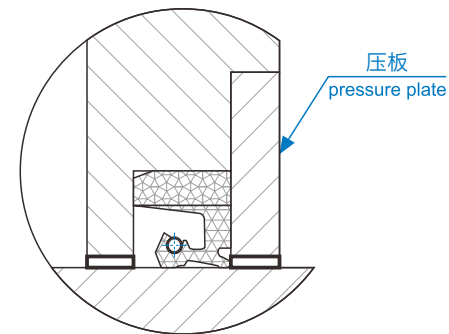

Figure 4-3 安装完成
Installation Completed

5

油封的维护

Maintenance of Oil Seals

5.1

日常维护注意事项

Precautions for Daily Maintenance

5.1.1 巡检周期 Patrol inspection period

油封安装在轴承座内部，日常不需要特别维护，主要以巡检为主，巡检的周期主要分为三个阶段。

The oil seal is installed inside the bearing seat. No special maintenance is required in daily life. Patrol inspection is the main method. The patrol inspection period is mainly divided into three phases.

Table 5-1 巡检周期
Patrol inspection period

| 序号 No. | 运行时间 runtime | 检查周期 patrol inspection period |
|-------------------|---|----------------------------------|
| 第一阶段 phase 1st | 运行一个月内 within one month of operation | 每一周 every week |
| 第二阶段 phase 2nd | 运行一年内 within one year of operation | 每一个月 every month |
| 第三阶段 phase 3rd | 运行一年后 after one year of operation | 每三个月 every three months |

5.1.2 巡检要点 Key point of patrol inspection

在日常巡检过程中主要检查两点：

In the process of daily patrol inspection, the main inspection points are as follows:

①油封是否出现漏油现象；

Whether oil leakage occurs in the oil seal;

②油封安装位置附近是否有大量橡胶磨屑产生。

Whether there is a large amount of rubber debris near the installation position of the oil seal.

如无此类现象出现，则说明密封件是处于正常工作状态；若出现上述两种现象，则需要做进一步检查。可咨询我司专业技术人员，也可先自行检查，并将检查报告抄送我司进行分析，具体操作步骤如下：

If there is no such phenomenon, it indicates that the sealing element is in normal working condition; If the above two phenomena occur, further inspection is required. You can consult our professional and technical personnel, or you can inspect by yourself first, and send the inspection report to our company for analysis. The specific operation steps are as follows:

①停机。

Stop the machine.

②将压板拆出并固定。

Remove the pressure plate and fix it.

③观察油封安装位置，注意观察问题出现点，如漏油位置、磨屑产生位置等，并一一

拍照做好相关记录。

Observe the installation position of the oil seal, pay attention to the points where problems occur, such as oil leakage position and abrasive dust generation position, and take photos one by one to make relevant records.

④通过一字螺丝刀等专用工具小心将密封件依次取出，观察油封是否完好无损，检

查油封弹簧是否脱落，特别是唇口部位是否损伤。

Take out the sealing elements one by one carefully through special tools such as a screwdriver, and observe whether the oil seal is in good condition and whether the oil seal spring falls off, especially whether the lip part is damaged.

⑤参照下图根据实际情况分析原因。

Refer to the following figure to analyze the reasons according to the actual situation.



Figure 5-1 由唇口部泄漏的主要原因
Schematic diagram of main causes of leakage from lip part

5.2

在线更换方法及步骤

Online Replacement Methods and Steps

油封的在线更换是一个系统性工程,需根据具体设备拟定相应的更换方案,如有需要请联系我司并提供以下内容。

The online replacement of oil seals is a systematic project, and the corresponding replacement plan should be drawn up according to specific equipment. Please contact our company and provide the following contents if you need it.

6

油封的存储

Storage of Oil Seals

6.1

油封在存储过程中可能遇到的危害

Possible Hazards of Oil Seals during Storage

6.1.1 环境要求 Environmental requirements

贮存场地温度应保持在10°C~25°C,平均湿度40%~70%。

The temperature of the storage site shall be kept at 10°C ~ 25°C, and the average humidity shall be 40% ~ 70%.

6.1.2 存放要求 Storage requirements

油封到货后若不立即使用,请尽量不要拆开包装纸箱,防止灰尘、沙粒等侵入损伤油封唇口。存放时纸箱应平放不能竖放。已经拆开纸箱的油封,应平放,不能竖放更不能挂起,特别是压迫唇口的挂起,请注意:油封的唇口是极易被损害的,细小的缺陷都可能是泄漏的潜在威胁。平放时,同规格可以叠放但应保持外圆重合,禁止不同规格产品叠放。为了防止下层产品挤压变形,同规格叠放数量不能大于10件。纸箱叠放不能超过4层。

If the oil seal is not used immediately after arrival, please try not to open the packing carton to prevent dust, sand and other particles from invading and damaging the lip of the oil seal. During storage, the carton should be placed horizontally instead of vertically. The oil seal in the unpacked carton should be placed horizontally instead of vertically or hung up, especially hung up when pressing the lip. Please note that the lip of the oil seal is extremely easy to be damaged, and small defects may be the potential threat of leakage. Oil seals of the same specifications can be stacked when they are placed horizontally, but the outer circle should be kept coincident. It is forbidden to stack products of different specifications. In order to prevent extrusion deformation of products on lower layers, no more than 10 pieces of products of the same specification shall be stacked. No more than 4 layers of cartons can be stacked.

6.1.3 放射性材料危害 Hazards of radioactive materials

油封应避免放射性材料及盐雾的侵害。

Oil seals shall be protected from radioactive materials and salt fog.

6.1.4 光化学危害 Photochemical hazards

为了延缓紫外线老化,油封应避免直射及反射的阳光。

In order to delay ultraviolet aging, oil seals should avoid direct and reflected sunlight.

6.1.5 臭氧危害 Ozone hazard

为了延缓臭氧老化,油封应避免能产生臭氧的设备及环境。

In order to delay ozone aging, oil seals should avoid equipment and environment that can generate ozone.

6.1.6 机械损伤 Mechanical damage

油封存放应避开工作区,避免下落物造成的机械损伤。

Oil seals shall be stored away from the working area to avoid mechanical damage caused by falling objects.

6.1.7 运输损伤 Transportation damage

油封运输需要使用纸箱或者木箱包装。包装箱应该和油封规格相匹配，保证油封在包装箱中无晃动颠簸和相互碰撞。

During transportation, oil seals need to be packed in cartons or wooden cases. The packing box should match the specifications of the oil seal to ensure that the oil seal does not shake, bump or collide with each other in the packing box.

6.2 油封的存储时间 Storage Period of Oil Seals

油封的仓储时间由仓储环境及油封主体材料决定，在理想的仓储环境下，油封的保管期限如下表所示。

The storage time of the oil seal is determined by the storage environment and the main material of oil seal. Under ideal storage environment, the storage period of oil seal is shown in the following table.

| 整制品材料 whole product material | 保管期限 storage period |
|---------------------------------|------------------------|
| 聚氨酯橡胶 PU | 3 年 years |
| 丁腈橡胶 NBR | 4 年 years |
| 聚丙烯酸酯橡胶 ACM | 7 年 years |
| 氢化丁腈橡胶 HNBR | 7 年 years |
| 三元乙丙橡胶 EPDM | 10 年 years |
| 氟橡胶 FKM | 10 年 years |

注：

- ① 使用长期贮存品，应确认无生锈情况；
- ② 橡胶制品表面上出现白粉末(起霜现象)，对性能无影响。

Note:

- ① When you use long-term storage products, you should confirm that there is no rust;
- ② White powder (frosting phenomenon) appears on the surface of rubber products has no influence on performance.